

INFRARED PYROMETER

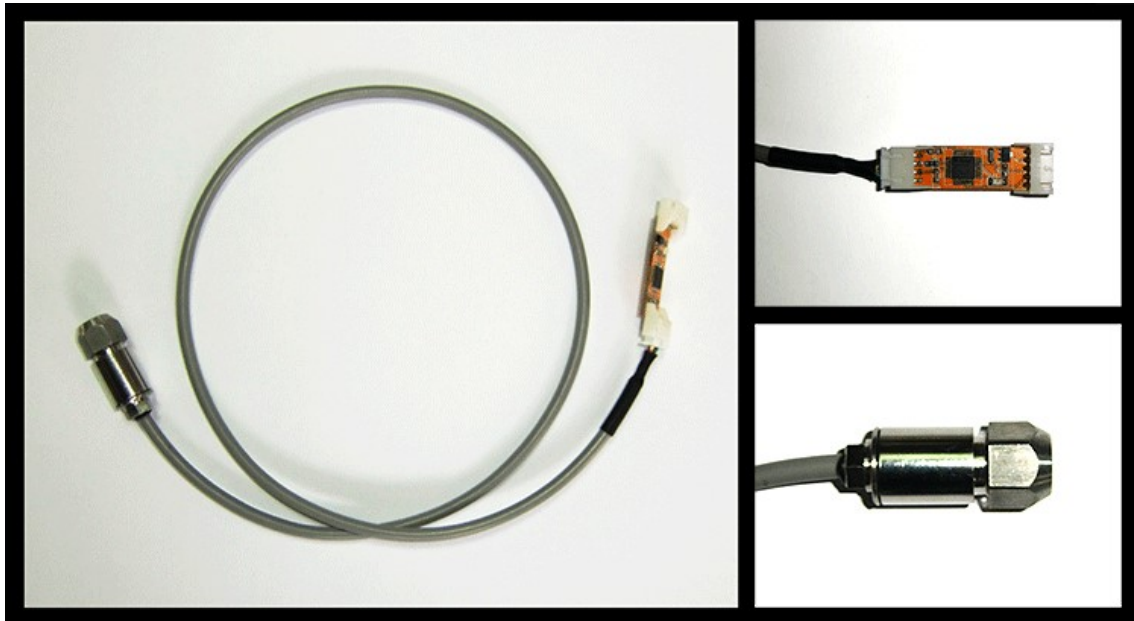

- **Measuring range: 25 - 500 °C / 25 - 1200 °C**
- **0... 3V DC linear analog output**
- **Resolution: 12 bits**
- **UART serial communication**
- **Supply voltage: 5 - 24V DC**
- **Infrared band: 1.5 - 12 um**
- **Configurable for metals / non-metals**

Applications:

- **Non contact temperature measurement**
- **Temperature Regulation**
- **Process Control**

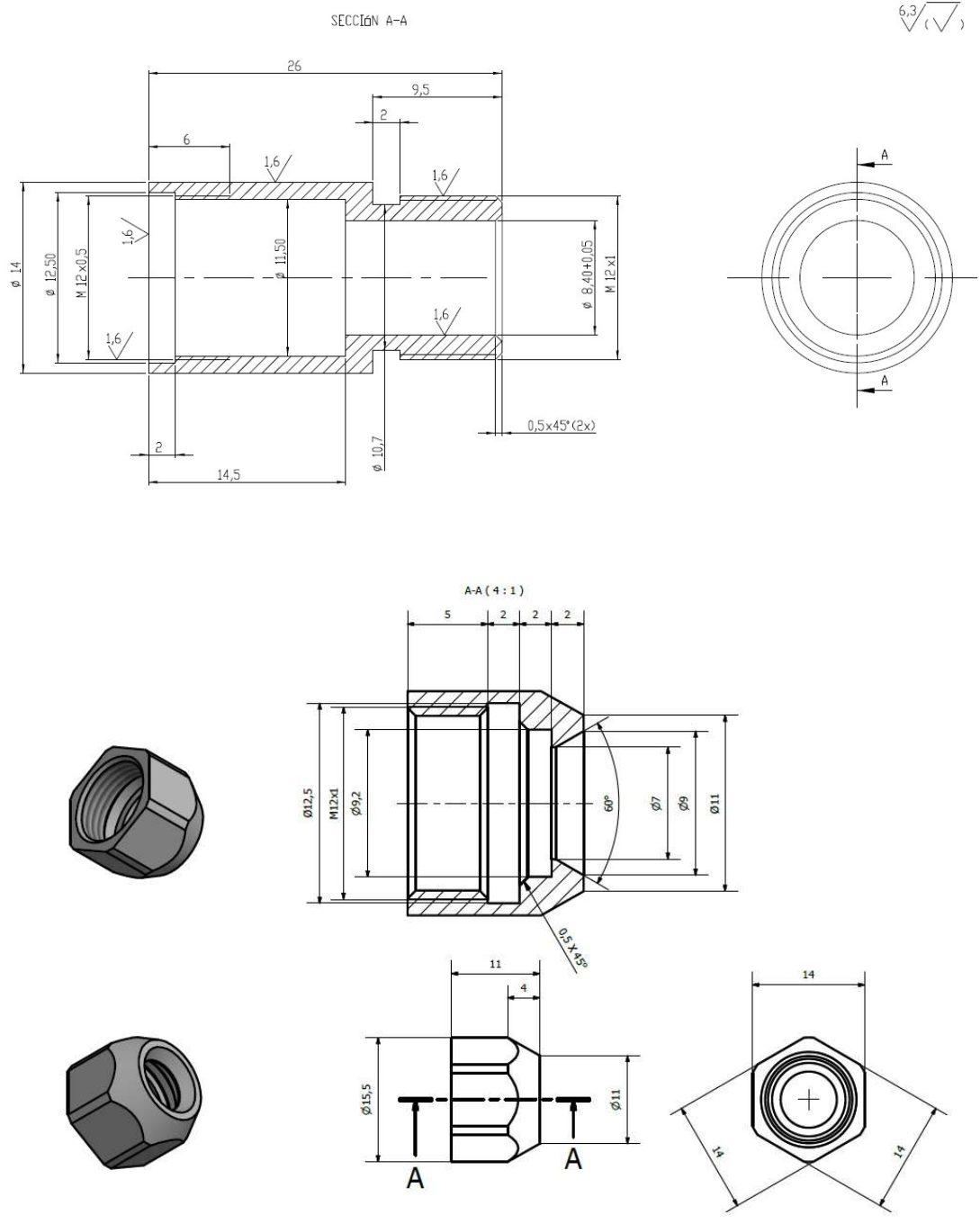

Fig.1. Dimensions.

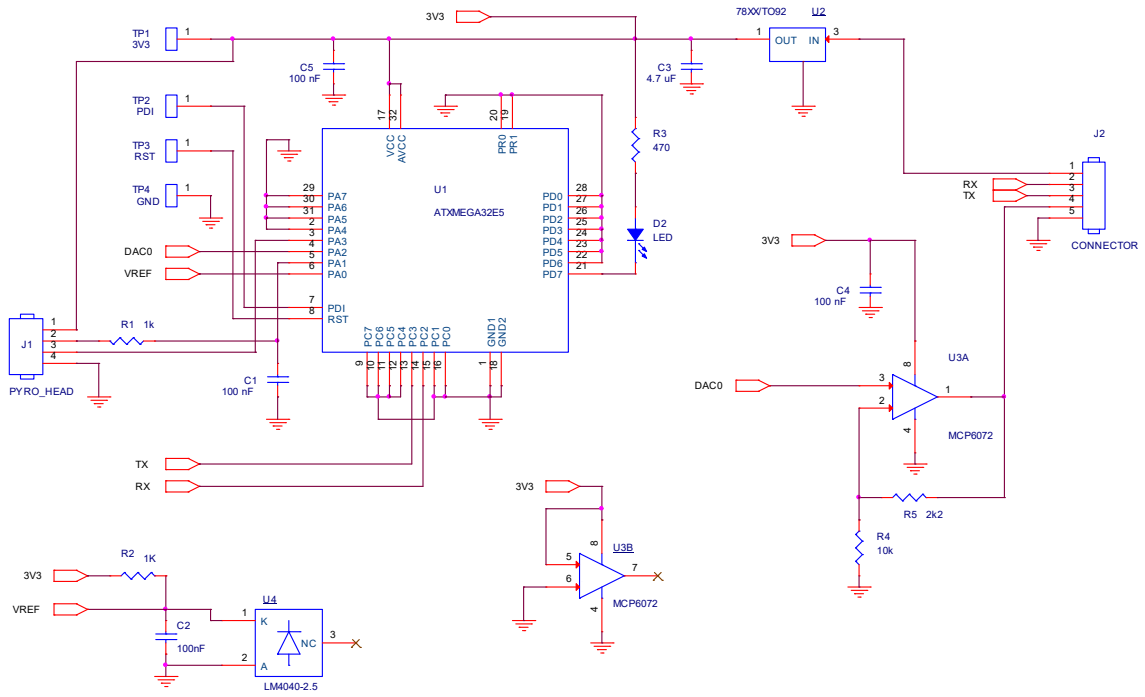

Fig.2. Digital Board Schematics.

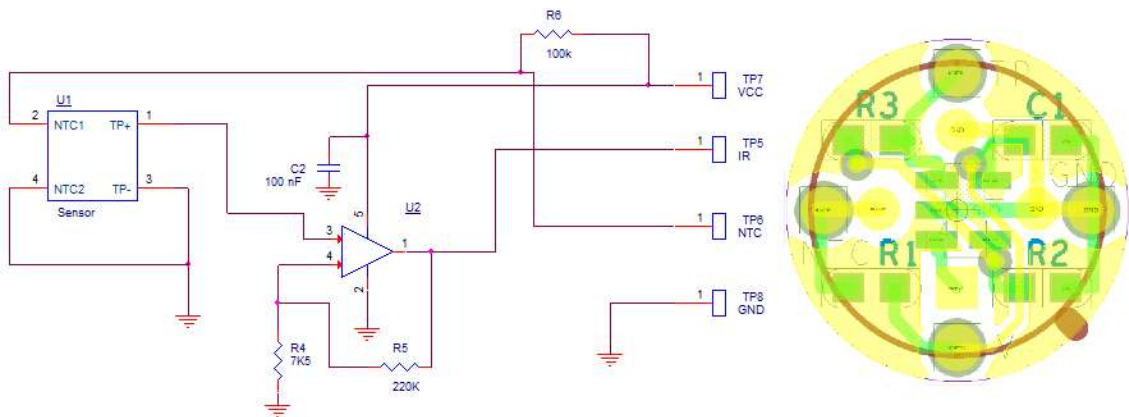

Fig.3. Pyro Head Electronics.

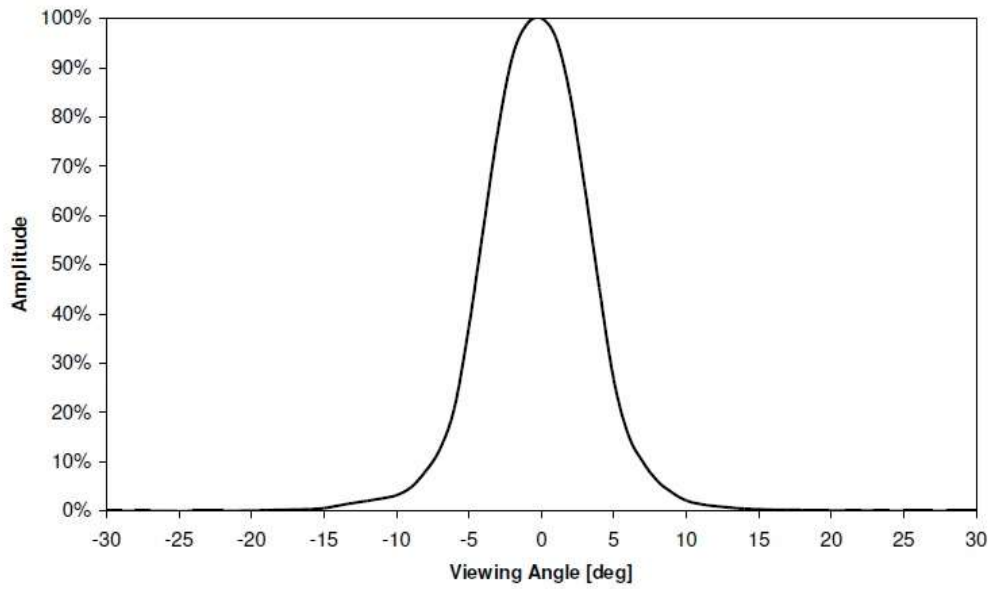

Fig.4. Optical Lens viewing angle-

**INFRARED
PYROMETER**

**For Industrial
Applications**

25 ... 1200 °C

ledoelectronics